

## SAP

Buffer tank with capacity from 75 to 3500 litres



### Features

- Buffer tank with pump fully assembled to be used together with water chillers. Hydraulic connections to be site installed
- Units dimensionally compatible with Aermec NBW, NRA, R, RV water chillers, but also compatible with any chiller
- Steel enclosure with epoxy powder coating for the maximum resistance to weathering
- Electric centrifugal pumps with stainless steel impeller
- Overpressure relief valve
- Fully insulated water circuit
- Pump motors protected by circuit breakers
- SAP 0075 and 0150 can be supplied with 5 different pump models with water flow rates up to 18,000 l/h and pressures up to 140 kPa (maximum 2 pumps can be installed internally)
- SAP 0300, 0500, 0501, 0750 and 1000 can be supplied with 8 models of pumps with water flow rates up to 60,000 l/h and pressures up to 200 kPa (pump set configurations with standby pump are possible). For correct sizing of the unit consult the technical manual.
- SAP 1500, 2500 and 3500 can be supplied with 10 models of pumps with water flow rates up to 200,000 l/h and pressures up to 300 kPa (pump set configurations with standby pump are possible). For correct sizing of the unit consult the technical manual.

### Accessories

- **AVX:** Spring anti-vibration mounts. Select the AVX model from the compatibility table included in the technical manual.
- **RX - RXV:** Electric immersion heater (RX: 500 W - RXV: 3 kW), installed and controlled by thermostats to prevent freezing during winter. **Factory fitted only.**
- **VT:** Anti-vibration mounts, set of four anti-vibration mounts to be installed under the unit's base.

SAP	Accessory compatibility			
	RX	RXV	VT 2	VT 8
0075	✓			✓
0150	✓			✓
0300	✓		✓	
0500 - 0501	✓		✓	
0750	✓		✓	
1000	✓		✓	
1500		✓		
2500		✓		
3500		✓		

## Connection Schematic Example

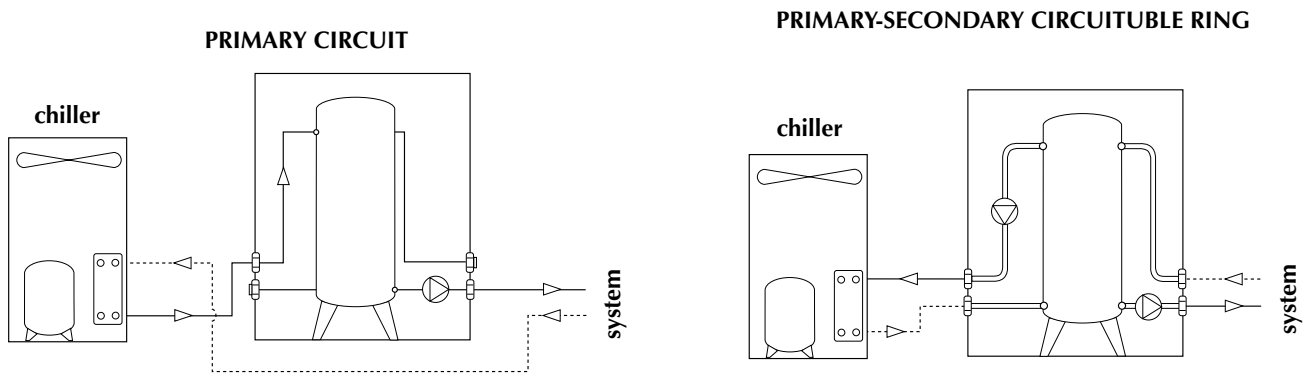

## Technical Data

Mod. SAP		0075	0150	0300	0500	0501
Capacity	l	75	150	300	500	500
Expansion tank capacity	l	8	12	18	24	24
Relief valve setting	bar	6	6	6	6	6
Water connections	(1)	F	F	F	F	F
Connection diameter	Ø	1" 1/4	1" 1/2	2"	2" 1/2	2" 1/2

Mod. SAP		0750	1000	1500	2500	3500
Capacity	l	750	1000	1500	2500	3500
Expansion tank capacity	l	18 x 2	18 x 2	24 x 2	24 x 3	24 x 3
Relief valve setting	bar	6	6	6	6	6
Water connections	(1)	F	F			
Connection diameter	Ø	3"	3"			

Model Pump	R	T	U	V	X	Y	W	K	J	I
1500 flange (*) Ø	125	125	150	150	150	150	200	200	200	200
2500 flange (*) Ø	125	125	150	150	150	150	200	200	200	200
3500 flange (*) Ø	125	125	150	150	150	150	200	200	200	200

Power supply = 3N~ 400V 50Hz.

(1) F = Female connection (Gas)

(\*) PN16UNI2278

## Technical Data

Pump motor power input													
Pump		A	B	C	E	F	G	H	I	J	K	L	M
Max. input power	W	275	330	614	895	1070	1550	2050	22000	17500	14500	3100	4100
Max. input current	A	0,5	0,69	1,1	1,6	1,9	2,8	3,6	43	36,4	30	5,6	7,2

Pump		N	P	Q	R	T	U	V	W	X	Y
Max. input power	W	1470	2600	5200	4000	5200	5800	8000	11500	9000	11000
Max. input current	A	2,6	4,4	8,8	8,5	11,5	15,5	15,5	22,5	22,5	22,5

Pump combinations												
SAP 0075	AC	AE	AF	AZ	BC	BE	BF	BZ	ZC	ZE	ZF	ZZ
SAP 0150	AC	AE	AF	AZ	BC	BE	BF	BZ	CC	CE	CF	CZ
	EC	EE	EF	EZ	FC	FE	FF	FZ	ZC	ZE	ZF	ZZ
SAP 0300						CS	CZ	ES	EZ	FS	FZ	ZZ
SAP 0500				FS	FZ	GS	GZ	HS	HZ	PS	PZ	ZZ
SAP 0501				FS	FZ	GS	GZ	HS	HZ	PS	PZ	ZZ
SAP 0750				FS	FZ	GS	GZ	HS	HZ	LS	LZ	MS
					MZ	NS	NZ	PS	PZ	QS	QZ	ZZ
SAP 1000				LS	LZ	MS	MZ	NS	NZ	QS	QZ	ZZ
SAP 1500		IS	IZ	JS	JZ	KS	KZ	RS	RZ	TS	TZ	US
			UZ	VS	VZ	WS	WZ	XS	XZ	YS	YZ	ZZ
SAP 2500		IS	IZ	JS	JZ	KS	KZ	RS	RZ	TS	TZ	US
			UZ	VS	VZ	WS	WZ	XS	XZ	YS	YZ	ZZ
SAP 3500		IS	IZ	JS	JZ	KS	KZ	RS	RZ	TS	TZ	US
			UZ	VS	VZ	WS	WZ	XS	XZ	YS	YZ	ZZ

**1st letter:** primary circuit.

**2nd letter:** secondary circuit.

**A, B** = multi-speed water pumps.

**L, M, Q** = twin pump set.

**S** = pump and standby pump set.

**Z** = without pump.

The combinations shown in the table are the only possible ones.

A large number of different flow rate/pressure combinations are available. Refer to the technical manual.

## Dimensions (mm)

SAP 0075 - 0150

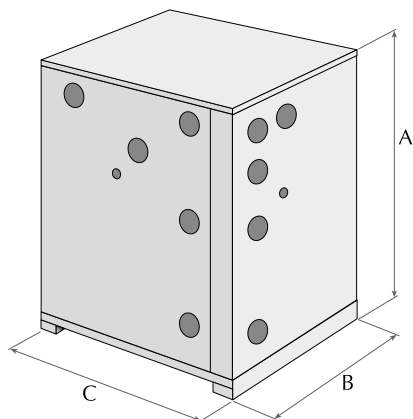

SAP 0300 - 0500

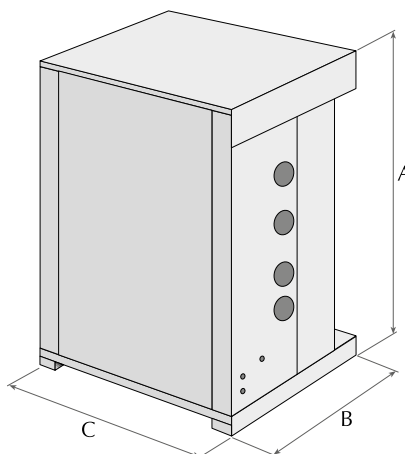

SAP 0501 - 0750

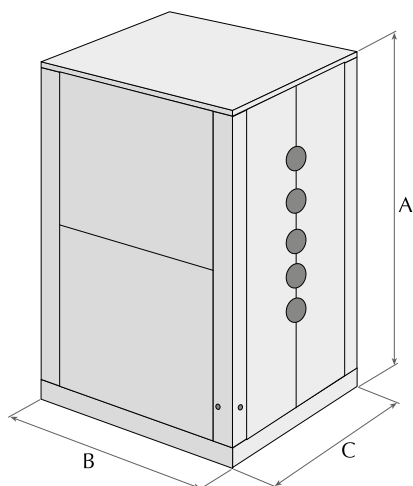

SAP 1000 - 1500 - 2500 - 3500

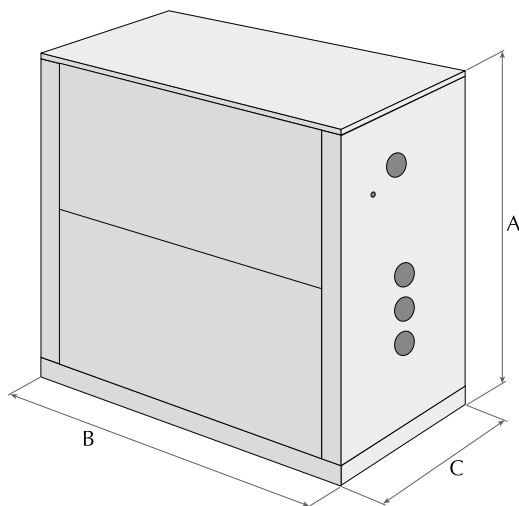

SAP		0075	0150	0300	0500	0501	0750	1000	1500	2500	3500
Height	A	1000	1000	1650	1650	1968	1968	2049	2049	2049	2049
Width	B	1000	1000	1100	1100	1550	1550	2200	2200	2200	2200
Depth	C	700	700	1100	1100	1000	1000	1000	1750	2000	2300
Net weight (ZZ version)	kg	120	120	190	230	310	400	445	560	710	790